

Graham

Fixed - 3 1/4" F-AW90



Architectural Products

Series: 6000

Manufacturing Code: 6011

Drawing 1/2 Scale - For Custom Size Drawing Contact Graham

Note: Sealant Not Shown On Details. Consult Technical Services At Factory For Sealing Procedures.

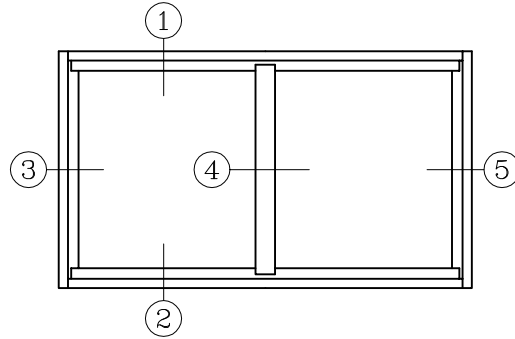
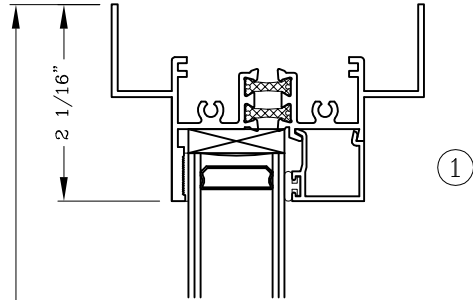

ELEVATION

Window Dimension

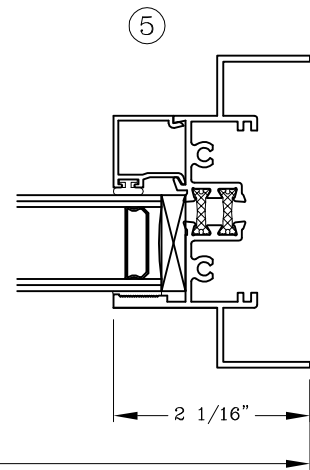
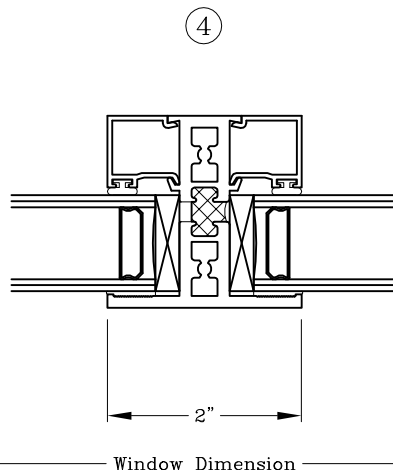
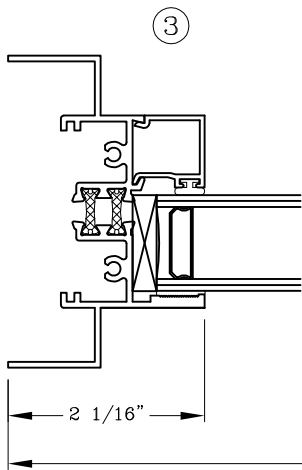
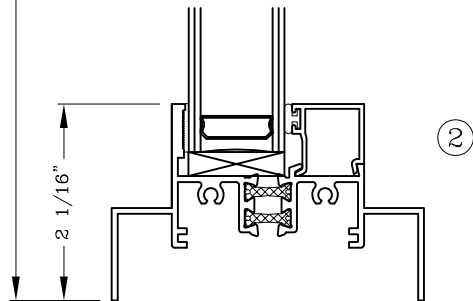

Window Dimension

Note: Dashed Lines Represent Inswing Vented Units Solid Lines Represent Outswing Vented Units; Lines Converge At Hinge Side Of Vent