

Graham

Double Hung Tilt - 4" H-AW55



Architectural Products

Series: 3100

Manufacturing Code: 3101

Drawing 1/2 Scale - For Custom Size Drawing Contact Graham

Note: Sealant Not Shown On Details. Consult Technical Services At Factory For Sealing Procedures.

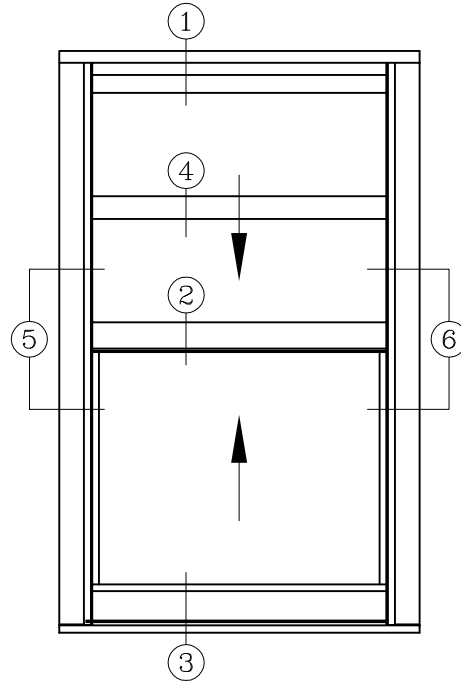
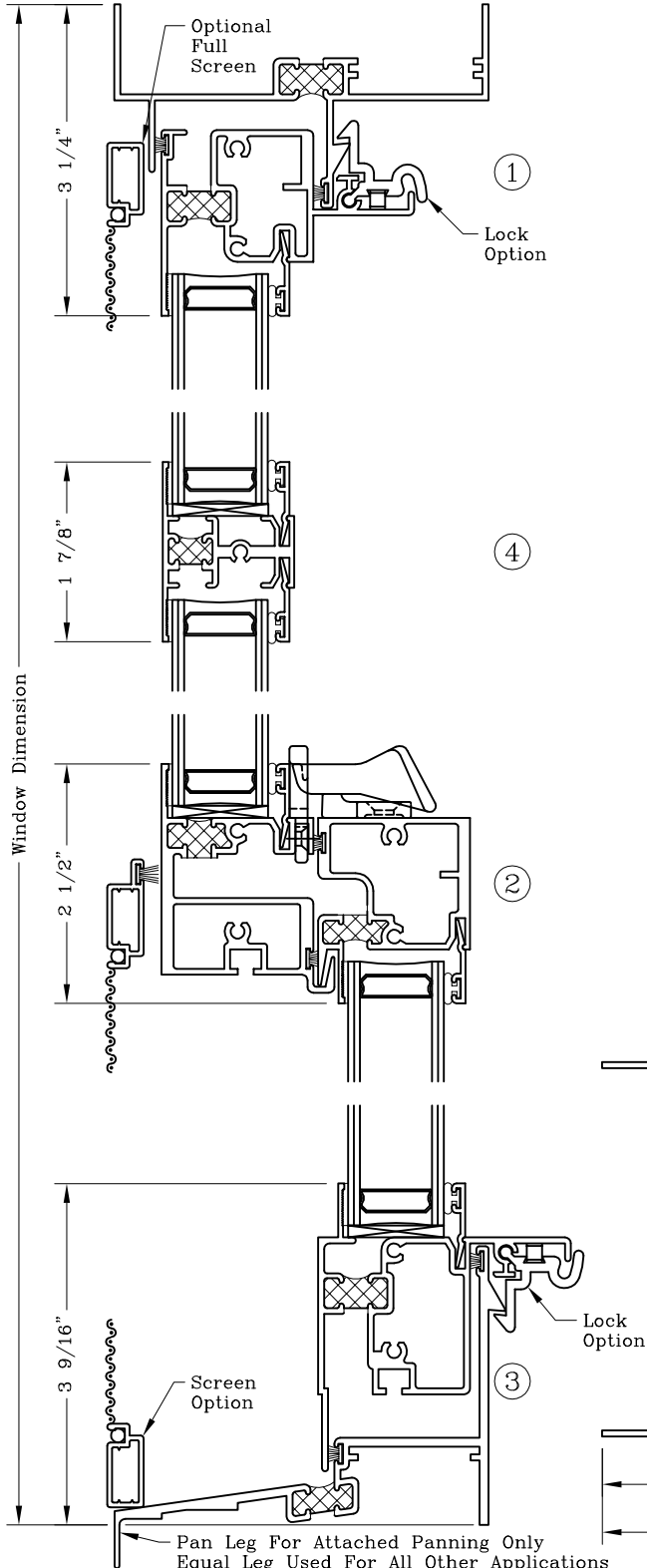

ELEVATION

Patent No. US 6,226,923 B1

