

Graham

Double Hung Side Load - 4" H-HC40



Architectural Products

Series: 2200

Manufacturing Code: 2209

Drawing 1/2 Scale - For Custom Size Drawing Contact Graham

Note: Sealant Not Shown On Details. Consult Technical Services At Factory For Sealing Procedures.

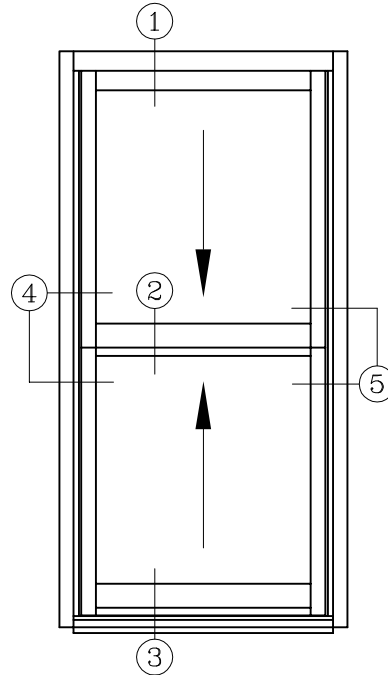
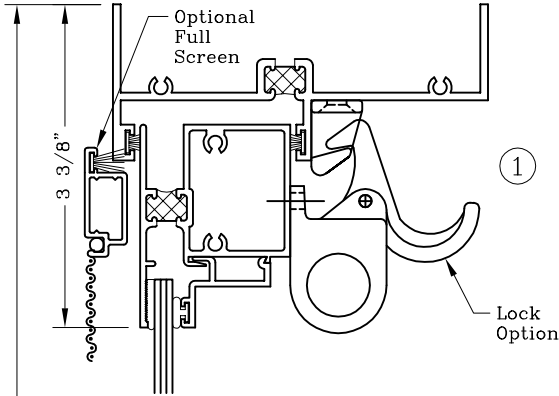

ELEVATION

Jamb Style Shown For Block And Tackle Balance

NOTE: Sweep Lock Not Available With Guardian Sash

