

Graham

Double Hung Side Load - 4" H-HC45



Architectural Products

Series: 2200

Manufacturing Code: 2201

Drawing 1/2 Scale - For Custom Size Drawing Contact Graham

Note: Sealant Not Shown On Details. Consult Technical Services At Factory For Sealing Procedures.

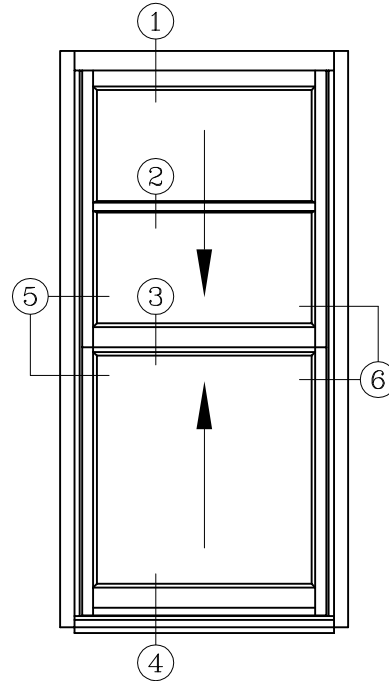
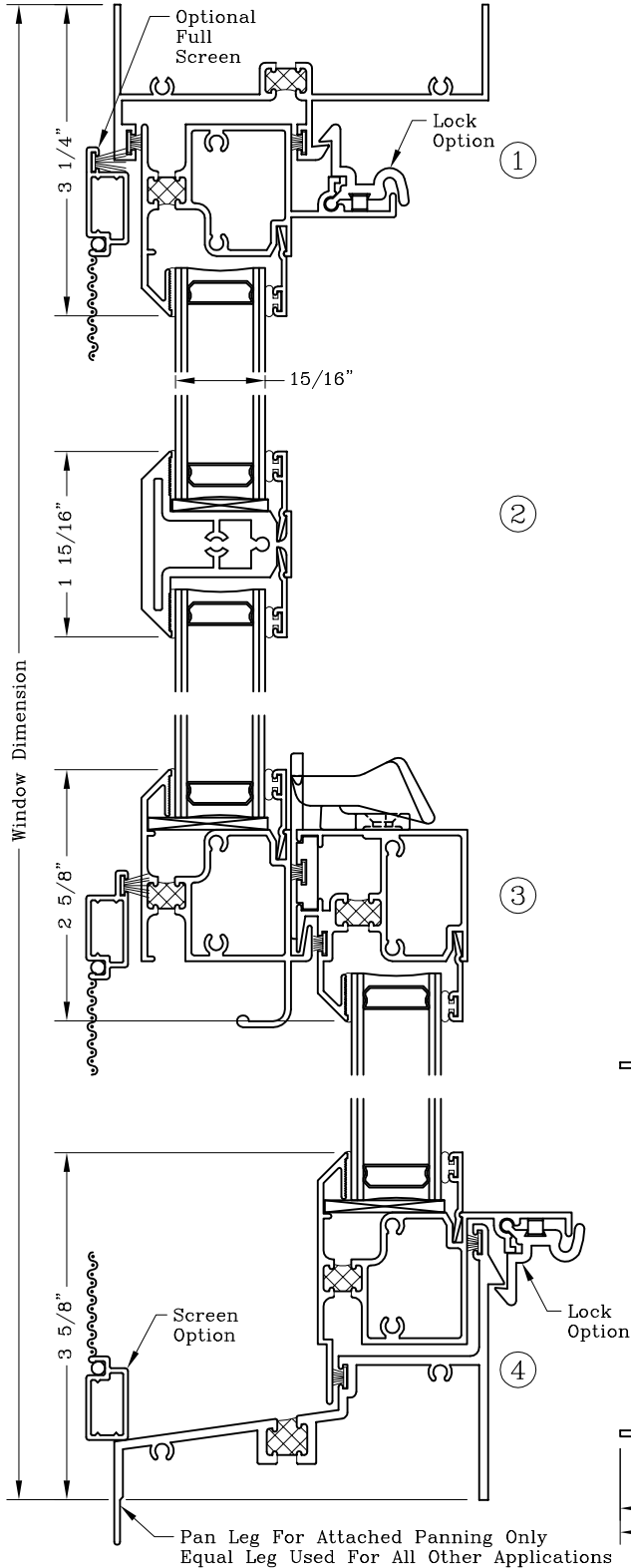

ELEVATION

Jamb Style Shown For Block And Tackle Balance

