

Graham

# Dual Fixed - 4 1/2"

F-DW-C80



Architectural Products

Series: 1100

Manufacturing Code: 1103

Drawing 1/2 Scale - For Custom Size Drawing Contact Graham

Note: Sealant Not Shown On Details. Consult Technical Services At Factory For Sealing Procedures.

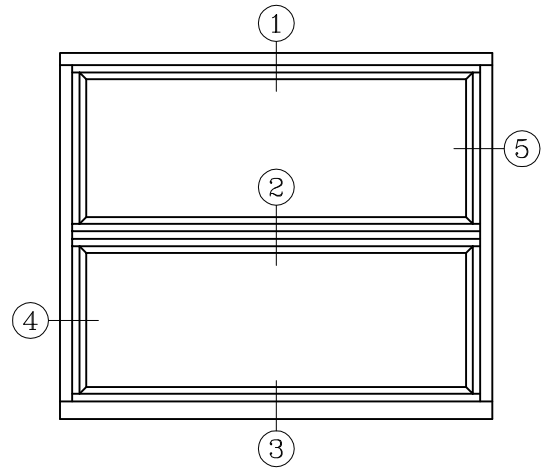
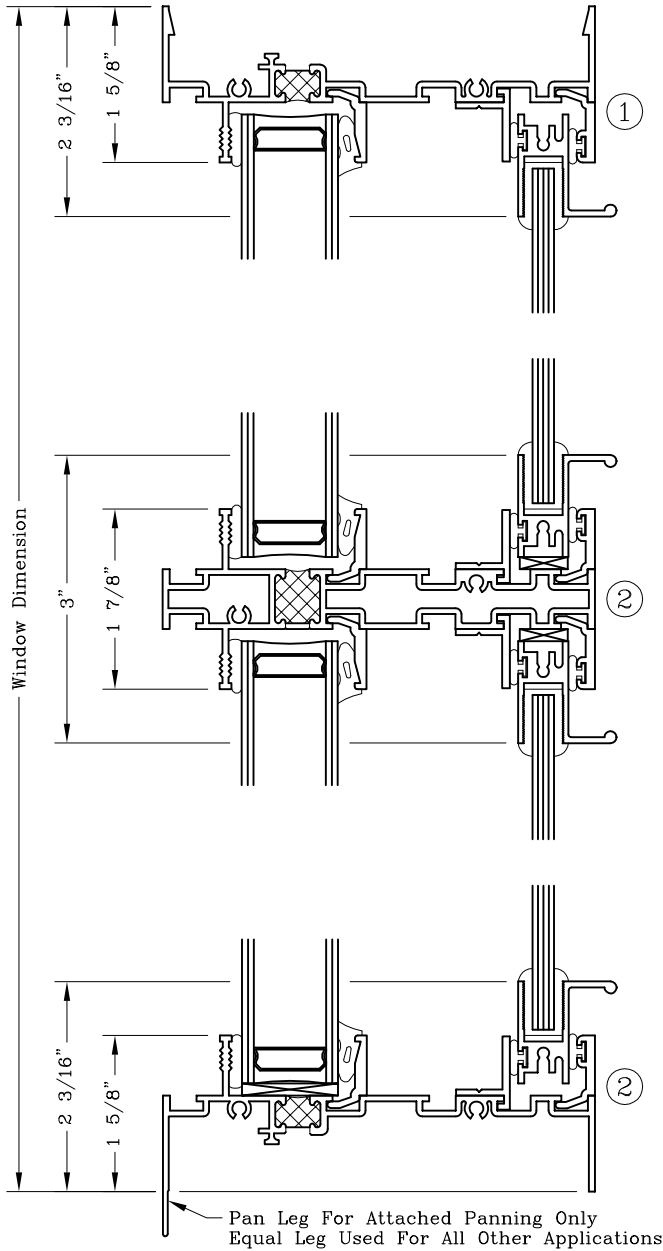

ELEVATION

Frame Options Available - Reference Frame Options Sheet 11.05

